

FoxLine



The FoxLine is a weatherproof luminaire for applications where high-quality, general-purpose lighting is required. Suitable applications include car parks, supermarkets, corridors, and evacuation passages.

The FoxLine features a robust weatherproof and impact-resistant construction with motion-detection and/or emergency system options.



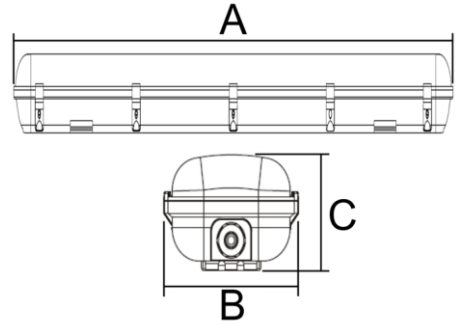

Features:

- Tough polycarbonate construction
- IP65 ingress rating for external environments
- High efficacy provides greater energy savings
- Reduced maintenance costs
- Internal gear tray hangers for safe & easy installation
- Spring loaded terminal for rapid installation

Specifications:

- Voltage Input: 240VAC
- Power Factor: ≥ 0.9
- Efficacy: ≥ 130 Lm/W
- Beam Angle: 120°
- CRI: ≥ 80
- Operating Temp: -20° to $+50^\circ\text{C}$
- Ingress Protection: IP65
- Impact Rating: IK09
- Dimmable: Dimmable options available
- Warranty: 5 years, first 3 years inclusive of labour

Options:

The options below are special order. Please contact Lumitex for more information.

- Colour temperature (CCT):
-3000K, 5000K

Part Number	Lumens (Lm)	Watts (W)	CCT (K)	Product Dimensions (mm)
LUMW12060840	1040	8	4000	A= 600 x B= 100 x C= 75mm
LUMW12121540	1950	15	4000	A=1200 x B=100 x C=75mm
LUMW12061540	1950	15	4000	A= 600 x B= 100 x C= 75mm
LUMW12123040	3900	30	4000	A=1200 x B=100 x C=75mm